

DFR-080-2

Fixed, Pressure-Compensated
Flow Regulator Valve

SERIES 8

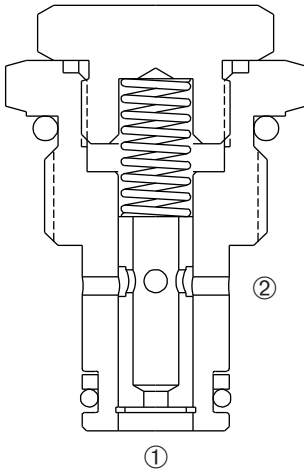
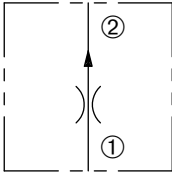

DESCRIPTION

A fixed cartridge valve designed to regulate flow regardless of load pressure. This valve is a restrictive-type flow regulator designed for low flow applications.

OPERATION

The DFR-080-2 maintains constant flow within specified accuracies from ① to ② regardless of downstream load pressure. When flow produces a minimum predetermined pressure differential across the compensator spool control orifice, the spool shifts against the spring force to throttle the flow and maintain the flow setting. Reverse flow is not regulated.

FEATURES and BENEFITS

- Pressure-compensated.
- Quiet response.
- Low flow capabilities.
- Industry common cavity.
- Compact size.

SPECIFICATIONS

Operating Pressure: 3000 PSI (207 Bar) A minimum pressure differential of 75 PSID is required to operate valve.

Flow: Ranges from 0.1 gpm to 2.0 gpm (0.4 to 7.6 L/min.)
(See ordering table)

Flow Tolerances: Flows 0.1 gpm to 1.5 gpm (0.4 to 5.7 L/min.)
±15% Flows over 1.5 gpm (5.7 L/min.) ±10%

Temperature: -30°F to +250°F (-35°C to +120°C)

Recommended Filtration: ISO 17/15/13

Fluids: Mineral-based fluids.

For other fluid compatibility, consult factory.

Cavity/Cavity Tool: 080-2, see page 11.08.2

In-Line Body Material: Anodized 6061T6 aluminum alloy rated at 3000 PSI (207 Bar).

PRESSURE DROP VS. FLOW

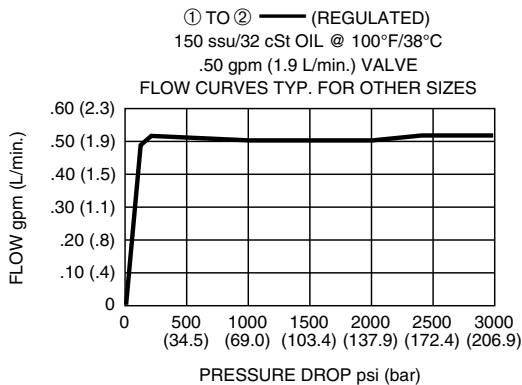

INSTALLATION DIMENSIONS

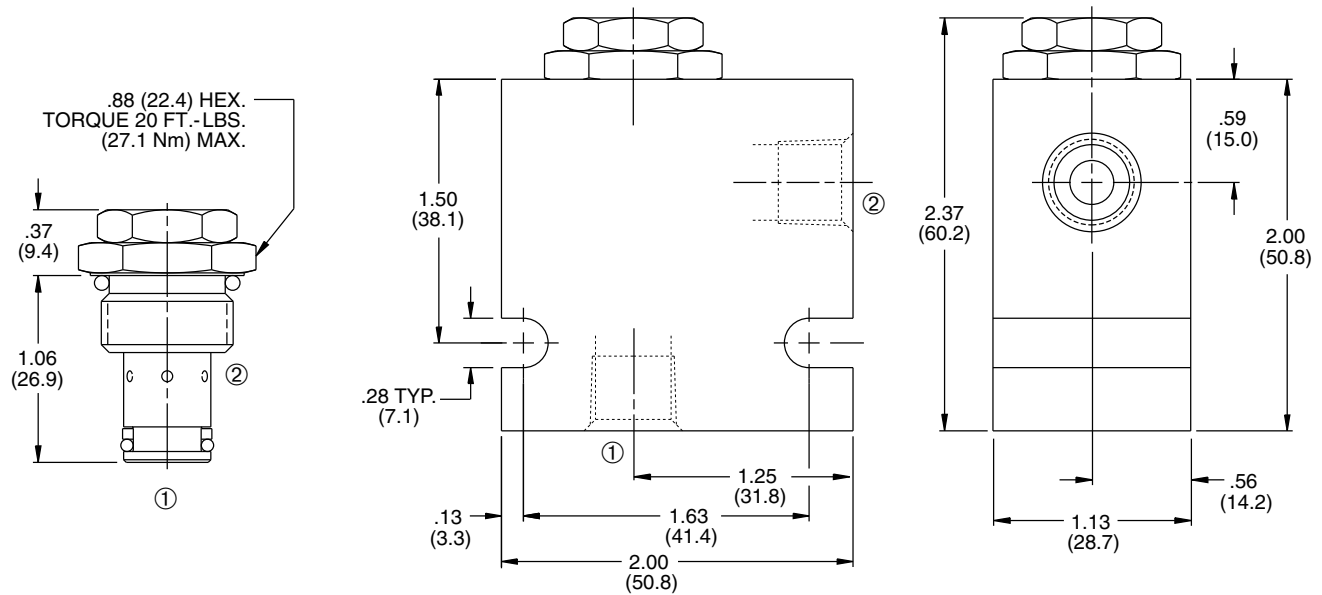

() Parentheses = Millimeters

HOW TO ORDER

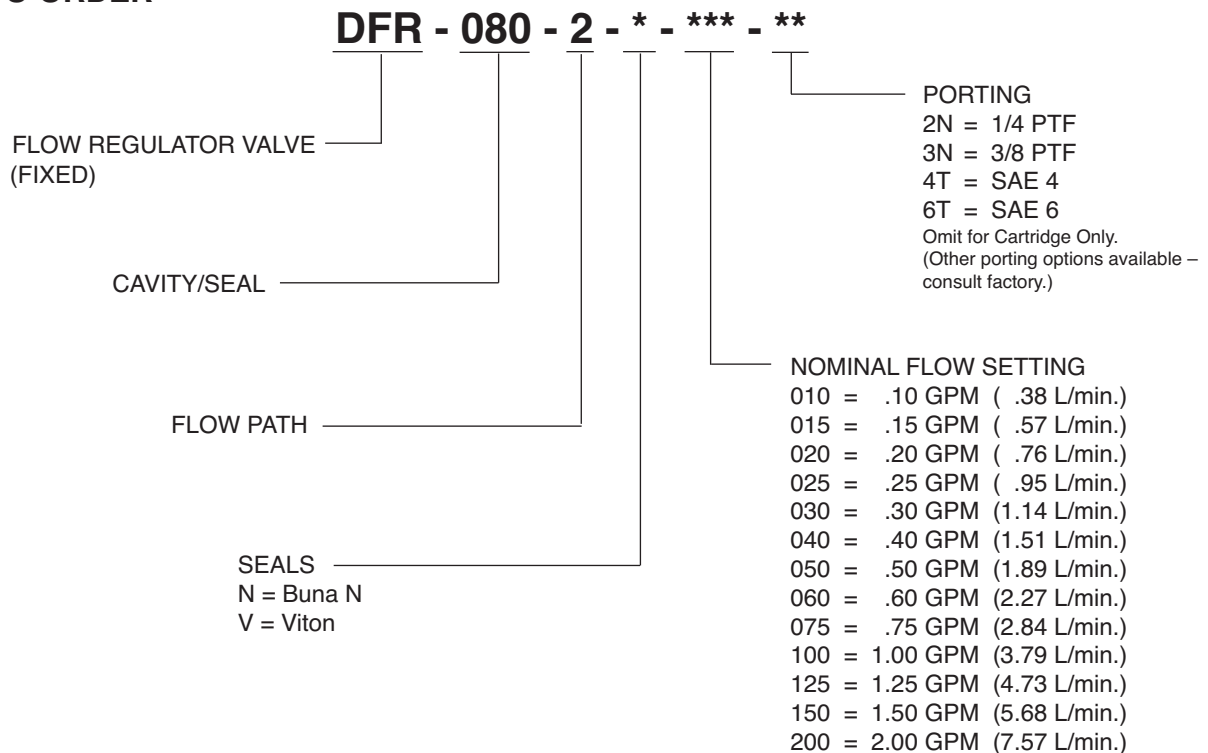

SOLENOID
CHECK
MOTION CONTROL
FLOW CONTROL
RELIEF
PRESSURE CONTROL
SEQUENCE
SHUTTLE
DIRECTIONAL VALVES
ACCESSORIES
TECHNICAL DATA