

DESCRIPTION

Pilot-Operated Check Valve. Check valves operate on slight differential pressure. Free flow is permitted in the direction of the arrow, positive check in the opposite direction. Reverse flow can be achieved by reaching the required pilot pressure at port (3).

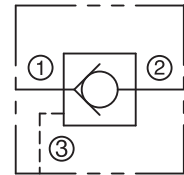

- For hydraulic applications only
- Air pilot valves have secondary seal on pilot piston stem. A vent hole in the body between the piston seal and stem seal prevents mixing of pilot media and the system media



SPECIFICATIONS

Maximum Operating Pressure

Carbon Steel: 3,000 psi (207 bar)

Operating Temperature Range

Buna-N: -30° to +200° F (-34° to +93° C)

Maximum Recommended Flow

6.0 to 12.0 gpm (22.7 to 45.4 lpm)

Pilot Ratio

- 4:1 Hydraulic Pilot
- 2:1 Hydraulic Pilot under 90 psi (6 bar)
- 2:1 Air Pilot

Threads

NPTF, BSPT

Materials

- Body: Steel
- Adapter: Steel
- O-Rings: Buna-N (PIC, PIDC)
Viton (APIDC)
- Piston: Steel
- Piston Spring: Music wire
- Check Spring: Stainless Steel 302
- Piston Seals: Teflon (PIC, PIDC)
Viton (APIDC)
- Teflon Back-up Washer (APIDC)
- Ball: Stainless Steel 440
- Ball Guide: Delrin®
- Washer: Stainless Steel 304
- Retainer Ring: Steel

INSTALLATION DIMENSIONS

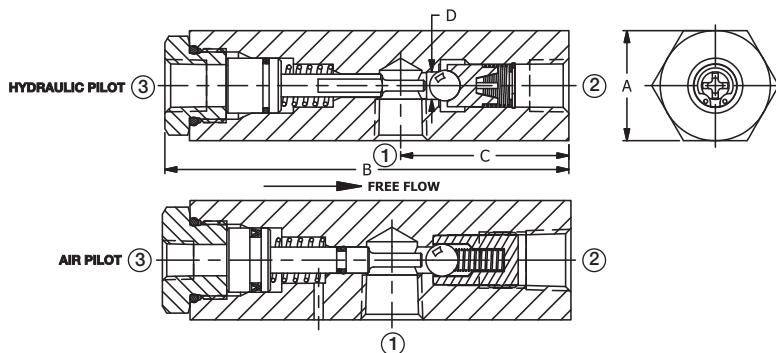

Pipe Size	A HEX	B	C	D orifice	Pilot Port	Inlet Port	Outlet Port
1/4"	1-1/8 (28.6)	4-1/8 (104.8)	1-27/32 (43.7)	.281 (7.1)	1/4"	1/4"	1/4"
3/8"	1-3/8 (34.9)	4-7/8 (123.8)	2-1/8 (54.0)	.328 (8.3)	1/4"	3/8"	3/8"
1/2"	1-5/8 (41.3)	5-5/8 (142.9)	2-7/16 (61.9)	.359 (9.1)	1/4"	1/2"	1/2"

() Parentheses = Millimeters

HOW TO ORDER

NPTF Thread			
Size	Air Pilot	Hydraulic Pilot	Max. Flow gpm (lpm)
1/4"	—	PIC20S	6.0 (22.7)
3/8"	—	PIDC25S	10.0 (37.9)
1/2"	APIDC30S	PIDC30S	12.0 (45.4)

ISO 7/1 – RS BSP Taper Thread		
Size	Hydraulic Pilot	Max. Flow gpm (lpm)
1/4"	PICB20S	6.0 (22.7)
3/8"	PICB25S	10.0 (37.9)